



TITAN FLOW CONTROL, INC.

**CHECK VALVE ♦ WAFER TYPE ♦ DUAL DISC****ASME CLASS 150 ♦ DUCTILE IRON BODY ♦ NSF COATING****MODEL: CV 41A-DI**

Body: Ductile Iron

Seats: Buna, Viton &amp; EPDM

Discs: Stainless Steel &amp; Aluminum Bronze

**NEWLY  
DESIGNED...**  
Meets API 594

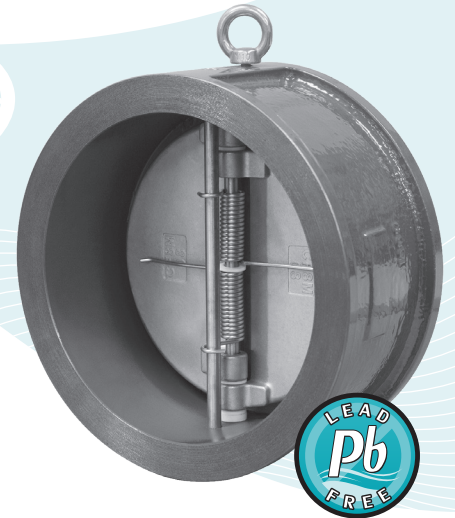
**FEATURES**

SIZES: 2" ~ 24"

LARGER SIZES AVAILABLE  
UPON REQUEST♦ **COMPLIES WITH API 594 DIMENSIONS**

THE CV41A-DI MEETS API 594 ASME CLASS 125 FACE-TO-FACE DIMENSIONS. THIS ALLOWS THE CV41A-DI TO BE A NATURAL REPLACEMENT FOR OUTDATED CAST IRON VALVES WHILE ACHIEVING THE SUPERIOR MATERIAL BENEFITS OF DUCTILE IRON.

♦ **NSF APPROVED COATING**

THE BODY OF THIS VALVE IS COATED WITH TNEC SERIES I41 EPOXOLINE. THIS COATING OFFERS HIGH-BUILD EDGE PROTECTION AND EXCELLENT CORROSION RESISTANCE. THIS COATING IS CERTIFIED BY NSF INTERNATIONAL IN ACCORDANCE WITH NSF/ANSI STANDARD 61.

♦ **DUCTILE IRON BODY**

DUCTILE IRON BODY MAINTAINS THE ANTI-CORROSIVE PROPERTIES OF CAST IRON WHILE ACHIEVING A YIELD STRENGTH COMPARABLE TO CARBON STEEL. DUCTILE IRON ALSO OFFERS HIGHER PRESSURE/TEMPERATURE RATINGS THAN CAST IRON.

♦ **COST EFFICIENT DESIGN**

LOW WEIGHT AND SHORT LAYING LENGTH PRODUCE SAVINGS IN INITIAL COST, SPACE REQUIREMENTS, AND INSTALLATION WHEN COMPARED TO FULL-BODY, SWING-TYPE CHECK VALVES.

♦ **MINIMAL HEAD LOSS**

CONTOUR OF BODY PROVIDES A SHORT AND STRAIGHT FLOW PATH THAT GENERATES VERY LITTLE TURBULENCE. ADDITIONALLY, THE SPRING-LOADED DISCS ARE DESIGNED WITH VERY LOW CRACKING PRESSURE WHICH REDUCES THE AMOUNT OF ENERGY REQUIRED TO OPEN THE VALVE.

♦ **QUICK CLOSURE TO REDUCE WATER HAMMER**

SHUT-OFF IS ACHIEVED VIA THE FULLY AUTOMATIC, SPRING-ASSISTED DISCS THAT CLOSE NEAR ZERO FLOW VELOCITY. THE LIGHTWEIGHT, SPLIT DISC DESIGN CREATES A POSITIVE SHUTOFF PRIOR TO FLOW REVERSAL AND HELPS TO KEEP SLAMMING AND SURGES TO A MINIMUM.

**TECHNICAL**

**PRESSURE/TEMPERATURE RATING**  
DI - ASTM A536 - CLASS 150 - 2" ~ 24"

WOG (Non-shock): 250 PSI @ 100 °F

**SEAT MATERIAL**  
**TEMPERATURE RANGE**

EPDM: -20 ~ 300 °F  
BUNA-N: -20 ~ 250 °F  
VITON: -40 ~ 400 °F

**SPRING MATERIAL**  
**MAXIMUM TEMPERATURE**

SS ASTM A182 Gr. 316: 450 °F

**APPLICATIONS**

**BUNA-N PROPERTIES:** MOST WIDELY USED ELASTOMER. GOOD FOR MOST PETROLEUM OILS AND FLUIDS, SILICONE GREASES AND OILS, AND COLD WATER. EXCELLENT COMPRESSION SET, TEAR, AND ABRASION RESISTANCE. POOR WEATHER RESISTANCE AND MODERATE HEAT RESISTANCE. NOT RECOMMENDED FOR SEVERE OZONE-RESISTANT APPLICATIONS.

**VITON PROPERTIES:** OFFERS A BROAD RANGE OF CHEMICAL RESISTANCE AND EXCELLENT HEAT RESISTANCE. GOOD MECHANICAL PROPERTIES AND COMPRESSION SET RESISTANCE. OFTEN USED IN APPLICATIONS WHERE NOTHING ELSE WILL WORK. FAIR LOW TEMPERATURE RESISTANCE AND LIMITED HOT-WATER RESISTANCE AND SHRINKAGE.

**EPDM PROPERTIES:** PROBABLY THE MOST WATER RESISTANT RUBBER AVAILABLE. IT HAS GOOD RESISTANCE TO MILD ACIDS, ALKALIS, SILICONE OILS/GREASES, KETONES, ALCOHOLS AND OTHER POLAR SOLVENTS. IT IS NOT RECOMMENDED FOR USE WITH PETROLEUM OILS, DI-ESTER LUBRICANTS, MINERAL OILS, NON-POLAR SOLVENTS OR AROMATIC FUELS.

*The above data represents common market and service applications. No representation or guarantee, expressed or implied, is given due to the numerous variations of concentrations, temperatures and flow conditions that may occur during actual service.*

**Commercial Industrial Supply****YOUR AUTHORIZED TITAN FLOW CONTROL DISTRIBUTOR!**

Tel: (866) 777-8001 Email: info@emailcis.com  
1444 E. Main St., Rock Hill, SC 29730 USA



**TITAN FLOW CONTROL, Inc.**

290 Corporate Drive  
Lumberton, NC 28358  
Tel: 910.735.0000

E-mail: titan@titanfci.com  
Web: www.titanfci.com  
Fax: 910.738.3848

**CHECK VALVE • WAFER TYPE • DUAL DISC**  
**MODEL: CV 41A-DI (Ductile Iron Body)**  
Buna-N, Viton, or EPDM Seats  
Stainless Steel or Bronze Discs

ASME  
Class  
150

**BILL OF MATERIALS <sup>(1)</sup>**

No.	PART	CV 41A-DI <sup>(3)</sup>
1	Body	Ductile Iron ASTM A536
2	Seat	Buna-N/Viton/EPDM
3	Disc <sup>(2)</sup>	Aluminum Bronze ASTM B148 / Stainless Steel ASTM A351 Gr. CF8M
4	Spring <sup>(2)</sup>	Stainless Steel ASTM A182 Gr. 316
5	Shaft/Stop Pin	Stainless Steel ASTM A182 Gr. 316
6	Set Screw	Galvanized Carbon Steel
7	Eye Bolt <sup>(4)</sup>	Carbon Steel (Not Shown)
8	Seal Plug	Buna-N/Viton/EPDM

1. Bill of Materials represents standard materials. Equivalent or better materials may be substituted at the manufacturer's discretion.  
2. Denotes recommended spare parts.  
3. Ductile Iron bodies are NSF coated.  
4. Eye Bolt is available on larger sizes only.

**Ductile Iron Application Notes:**

Ductile Iron maintains the anti-corrosive properties of Cast Iron while achieving a yield strength comparable to Carbon Steel. Ductile Iron also offers higher pressure/temperature ratings than Cast Iron. Ductile Iron ASME Class 150 has the same bolting pattern as Cast Iron ASME Class 125.

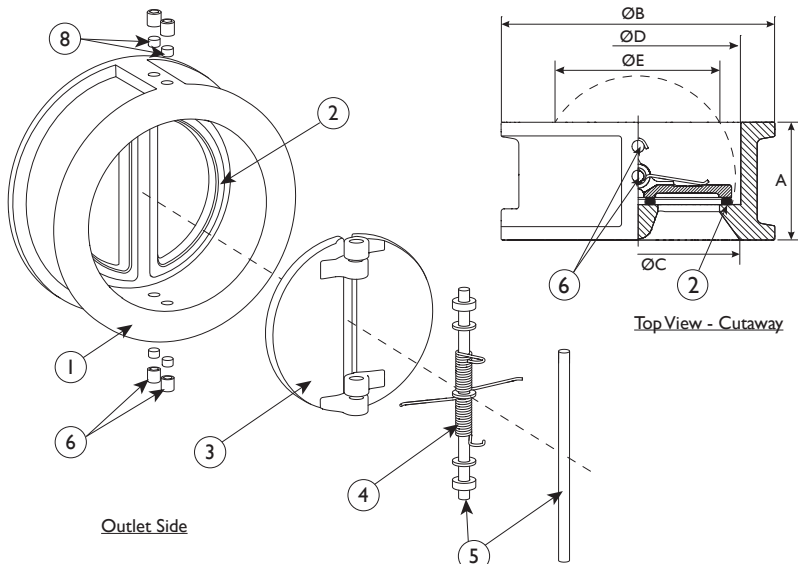

**DIMENSIONS AND PERFORMANCE DATA <sup>(1)</sup>**

SIZE	in	2	2 1/2	3	4	5	6	8	10	12	14	16	18	20	24
		mm	50	65	80	100	125	150	200	250	300	350	400	450	500
<b>A DIMENSION</b> FACE TO FACE <sup>(2)</sup>	in	2.12	2.38	2.62	2.62	3.25	3.75	5.00	5.50	7.12	7.25	7.50	8.00	8.38	8.75
	mm	54	60	67	67	83	95	127	140	181	184	191	203	213	222
<b>ØB DIMENSION</b> OUTLET OUTSIDE DIAMETER	in	4.02	4.76	5.24	6.73	7.60	8.62	10.87	13.23	15.98	17.64	20.12	21.50	23.74	28.11
	mm	102	121	133	171	193	219	276	336	406	448	511	546	603	714
<b>ØC DIMENSION</b> INLET INSIDE DIAMETER	in	2.17	2.92	3.45	4.12	5.67	6.43	8.56	10.43	12.21	14.17	16.13	17.32	20.10	23.66
	mm	55	74	88	105	144	163	217	265	310	360	410	440	511	601
<b>ØD DIMENSION</b> OUTLET INSIDE DIAMETER	in	2.58	3.15	3.70	4.61	5.71	6.69	8.82	10.43	12.20	14.17	16.14	17.72	19.88	24.57
	mm	66	80	94	117	145	170	224	265	310	360	410	450	505	624
<b>ØE DIMENSION</b> MINIMUM BORE DIAMETER	in	1.66	2.28	2.78	3.38	4.53	5.49	7.40	9.14	10.65	12.97	14.63	16.26	18.17	22.62
	mm	42	58	71	86	115	140	188	232	271	330	372	413	462	575
<b>ASSEMBLED WEIGHT</b>	lb	3.3	5.2	7.0	14.0	18.0	26.5	43.0	70.0	108.0	175.0	200.0	258.0	345.0	460.0
	kg	1.5	2.4	3.2	6.4	8.2	12.0	19.5	31.7	48.9	79.4	90.7	117.0	156.5	208.7
<b>Flow Coefficient</b>	C <sub>v</sub>	62	110	175	350	550	850	1500	2400	3700	5400	8250	10400	14200	23000
<b>Cracking Pressure <sup>(3)</sup></b>	psi	≤ .25	≤ .25	≤ .25	≤ .25	≤ .25	≤ .25	≤ .25	≤ .25	≤ .25	≤ .25	≤ .25	≤ .25	≤ .25	≤ .25

1. Dimensions and weights are for reference only. When required, request certified drawings.  
2. Face to face values have a tolerance of ±0.06 in (±2.0 mm) for sizes 10" and lower and a tolerance of ±0.12 in (±3.0 mm) for sizes 12" and larger.

3. Cracking pressure is for horizontal installations only. For vertical installations, please consult factory.

**PRESSURE - TEMPERATURE RATINGS <sup>(1)</sup>**

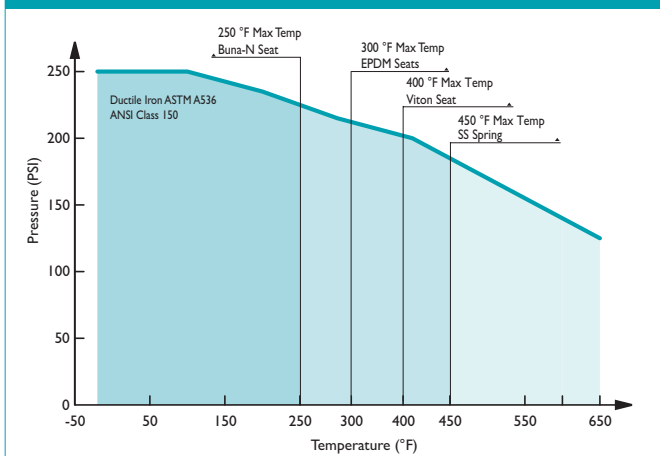

1. The above chart displays the pressure-temperature ratings for the valve's body material per ASME B16.42. Max temperature limits have been added for seat and spring materials.

Titan FCI makes every effort to ensure the information presented on our literature accurately reflects exact product specifications. However, as product changes occur, there may be short-term differences between actual product specifications and the information contained within our literature. Titan FCI reserves the right to make design and specification changes to improve our products without prior notification. When required, request certified drawings.

**REFERENCED STANDARDS & CODES**

CODE	DESCRIPTION
API 594	Valve Design and Manufacture
ASME B16.5	Pipe Flanges and Flanged Fittings
ASME B16.34	Valves - Flanged, Threaded, and Welding End
ASME B16.42	Ductile Iron Pipe Flanges and Flanged Fittings
API 598	Valve Inspection and Pressure Test

**PRESSURE / TEMPERATURE RATING - ASTM A536**

<b>Body Material</b>	<b>Class 150 (2" ~ 24")</b>
WOG (Non-shock):	250 PSI @ 100 °F

**SEAT AND SPRING TEMPERATURE RATING**

Seat Material	Range	Spring Material	Max
EPDM:	-30 ~ 300 °F	SS ASTM A182 Gr. 316:	450 °F
BUNA-N:	-20 ~ 250 °F		
VITON:	-40 ~ 400 °F		